

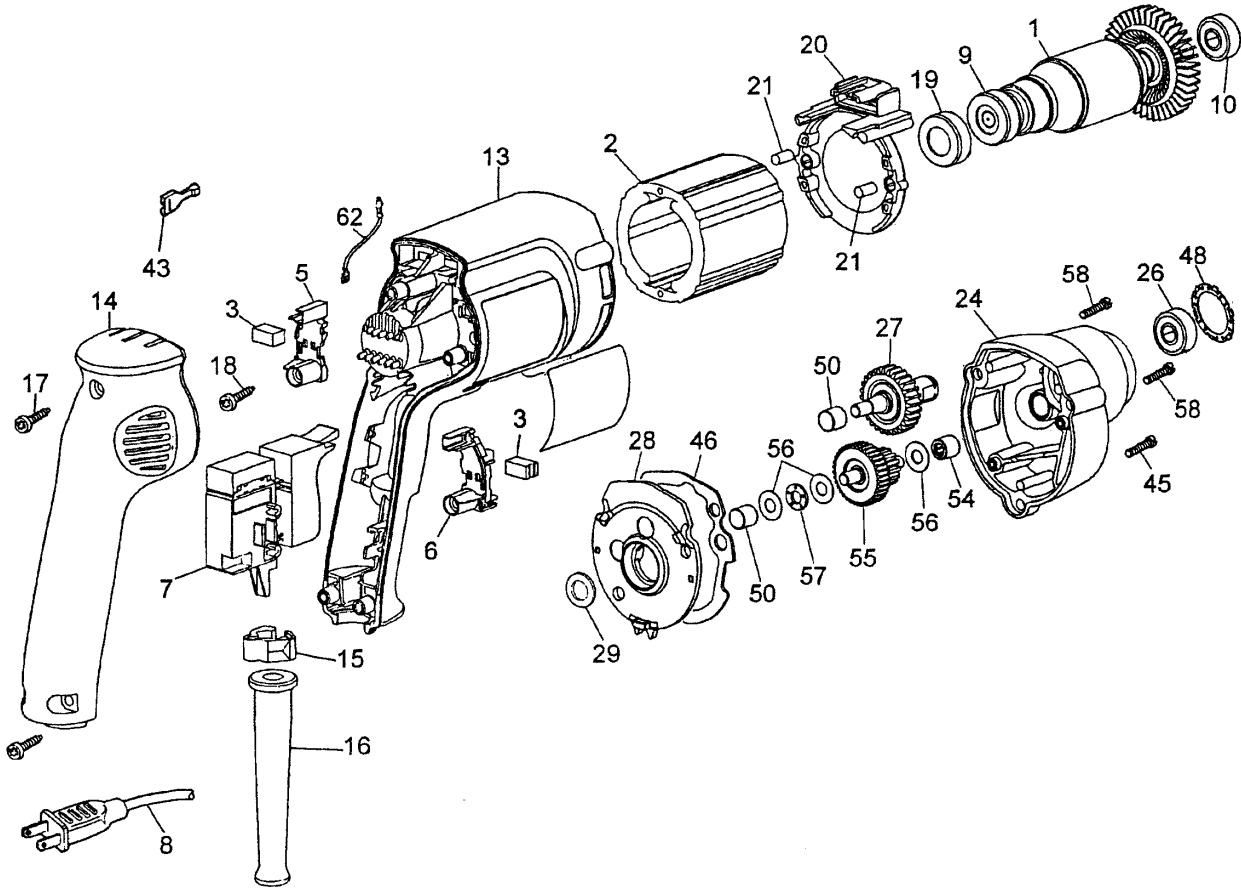

**Component Motor Unit Model 253-55**  
 Used on KD-200, KD-242, KD-270, KD-280, KD-290 and KD-292 Shears;  
 KS-221, KS-224, and KS-226 Saws

# PARTS LIST



ITEM NO.	PART NO.	DESCRIPTION	REQ'D TOOL
1	382299-01	Armature & Fan (6 Teeth)	1
2	176883-00	Field	1
3	176846-02	Brush	2
4	176801-02	Left Brush Holder (gray)	1
5	176800-02	Right Brush Holder (black)	1
7	176830-13	Switch	1
*8	330072-98	Cord & Plug (18-2SJ)	1
*9	176950-00	Ball Bearing	1
*10	176950-00	Ball Bearing	1
13	396969-09	Field Case	1
14	176899-02	Handle Cover	1
*15	176829-00	Cord Clamp	1
16	330005-01	Cord Protector	1
*17	330019-13	Screw	3
*18	176951-00	Screw	2
*19	389824-00	Cup	1
20	176811-01	Baffle	1
21	949638-02	Rubber Plug	2
*24	388657-01	Gear Case	1
*26	330003-09	Ball Bearing	1
27	388668-01	Spindle & Gear	1
*28	176650-00	Gear Case Cover	1
*29	23813-00	Fiber Washer	1
43	136086-02	Terminal	3
*45	330019-14	Screw	1
46	176655-00	Gasket	1
*48	87692-00	Bearing Retainer	1

ITEM NO.	PART NO.	DESCRIPTION	REQ'D TOOL
*50	93128-00	Needle Bearing	2
*54	93129-00	Needle Bearing	1
55	176731-00	Pinion & Gear (15/37 teeth)	1
56	176732-00	Thrust Washer	3
57	143079-00	Thrust Washer	1
*58	330019-16	Screw	2
62	176860-00	Lead	1

**\*NOTES:**

- 8,15 Cord clamp should be positioned, so that 30mm of cord jacket extends above the clamp.
- 9 Seal to face commutator. Press to the tubing on armature shaft.
- 10 To remove from shaft, place bearing in vise and crush outer race. Remove all internal bearing components, so that the inner race is all that is left. Use SRT320, Small Bearing Separator, to clamp the inner race and press off. Bearing presses to shoulder.
- 17,45,58 Torque to 18-23 inch-lbs.
- 18 Torque to 13 inch-lbs.
- 19 Small diameter end to face commutator.
- 24 Includes 26,48 and 54.
- 26 Press Bearing until seated completely in pocket. Rubber seal to face spindle and gear assembly.
- 28 Includes 10 and 50.
- 29 Press to bearing (item 10).