

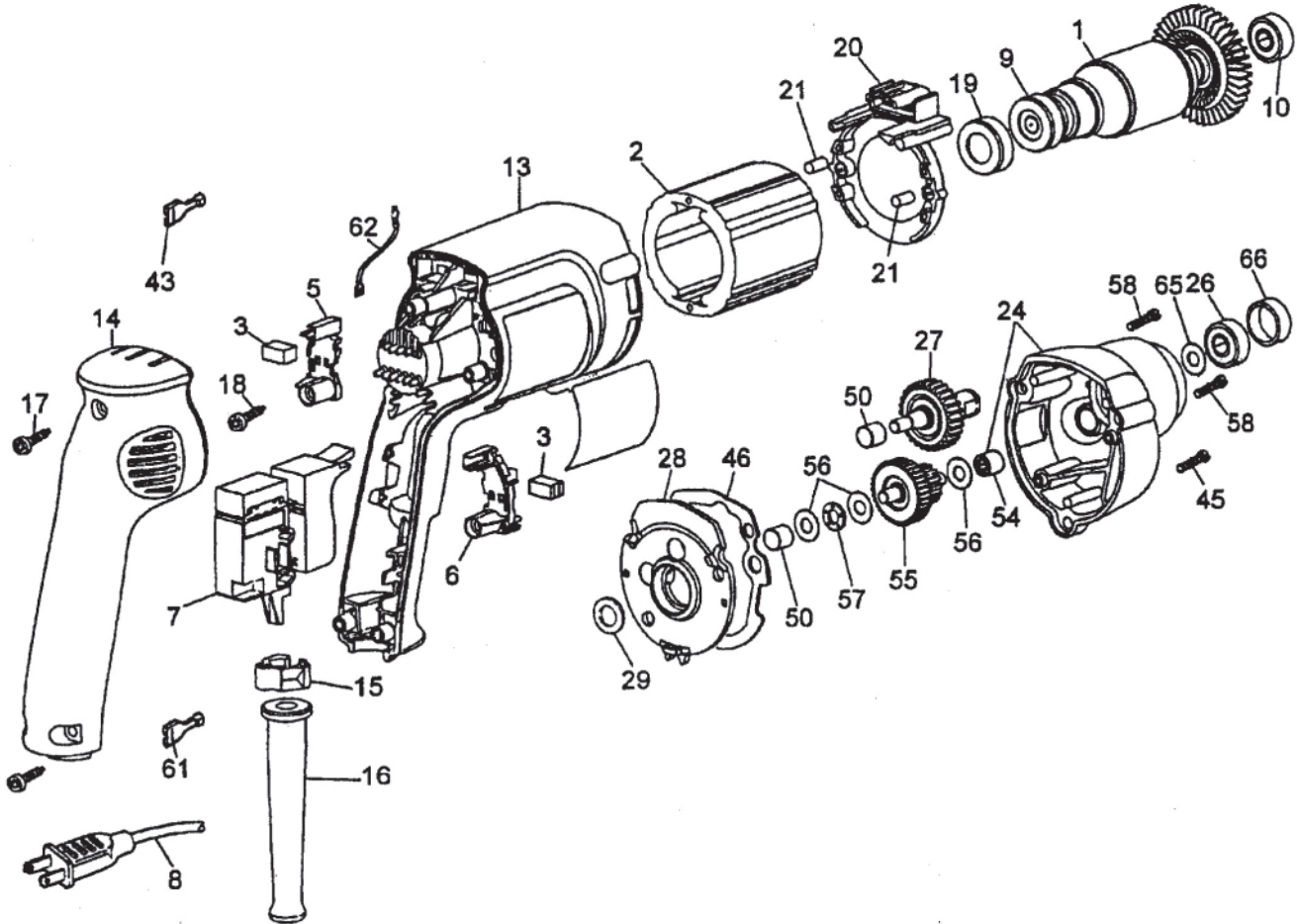

Component Motor Unit Model 253-59

Used on KD-440, KD-441, KD-442, KD-493 and KD-495 Shears
 KS-423, KS-424, KS-426 and KSV-432 Saws

PARTS LIST



ITEM NO.	PART NO.	DESCRIPTION	REQ'D TOOL	ITEM NO.	PART NO.	DESCRIPTION	REQ'D TOOL
1	382299-01	Armature & Fan (6 Teeth)	1	*54	93129-00	Needle Bearing	1
2	176883-00	Field	1	55	176731-00	Pinion & Gear (15/37 teeth)	1
3	176846-02	Brush	2	56	176732-00	Thrust Washer	3
5	176801-02	Left Brush Holder (gray)	1	57	143079-00	Thrust Washer	1
6	176800-02	Right Brush Holder (black)	1	*58	330019-16	Screw	2
7	176830-39	Switch	1	61	136086-08	Terminal	2
*8	330072-98	Cord & Plug (18-2SJ)	1	62	176860-00	Lead	1
*9	176950-00	Ball Bearing	1	65	449892-00	Washer	1
*10	176950-00	Ball Bearing	1	66	449368-00	Bearing Cap	1
13	396969-09	Field Case	1	*NOTES: 8, 15 Cord clamp should be positioned, so that 30mm of cord jacket extends above the clamp. 9 Seal to face commutator. Press to the tubing on armature shaft. 10 To remove from shaft, place bearing in vise and crush outer race. Remove all internal bearing components, so that the inner race is all that is left. Use SRT320, Small Bearing Separator, to clamp the inner race and press off. Bearing presses to shoulder. 17,45,58 Torque to 18-23 inch-lbs. 18 Torque to 13 inch-lbs. 19 Small diameter end to face commutator. Lightly lubricate before installing into field case. 26 Press Bearing until seated completely in pocket. Rubber seal to face spindle and gear assembly. 28 Includes 10 and 50. 29 Press to bearing (item 10). 54 Press flush with surface facing spindle and gear assembly.			
14	176899-02	Handle Cover	1				
*15	176829-00	Cord Clamp	1				
16	330005-01	Cord Protector	1				
*17	330019-13	Screw	3				
*18	176951-00	Screw	2				
*19	389824-00	Cup	1				
20	176811-01	Baffle	1				
21	949638-02	Rubber Plug	2				
*24	388657-00	Gear Case	1				
*26	330003-09	Ball Bearing	1				
27	388668-00	Spindle & Gear	1				
*28	176650-00	Gear Case Cover	1				
*29	23813-00	Fiber Washer	1				
43	136086-02	Terminal	4				
*45	330019-14	Screw	1				
46	176655-00	Gasket	1				
*50	93128-00	Needle Bearing	2				



KSV-33 SAW UNIT

FOR TOOLS MADE AFTER DECEMBER, 2012 WITH NEW STYLE DEPTH STOP

PARTS LIST

* Use 267-45 Sleeve on KSV-33AM

* Use 567-2A Sleeve on KSV-32AM, KSV-432 and PSV-532 Saws

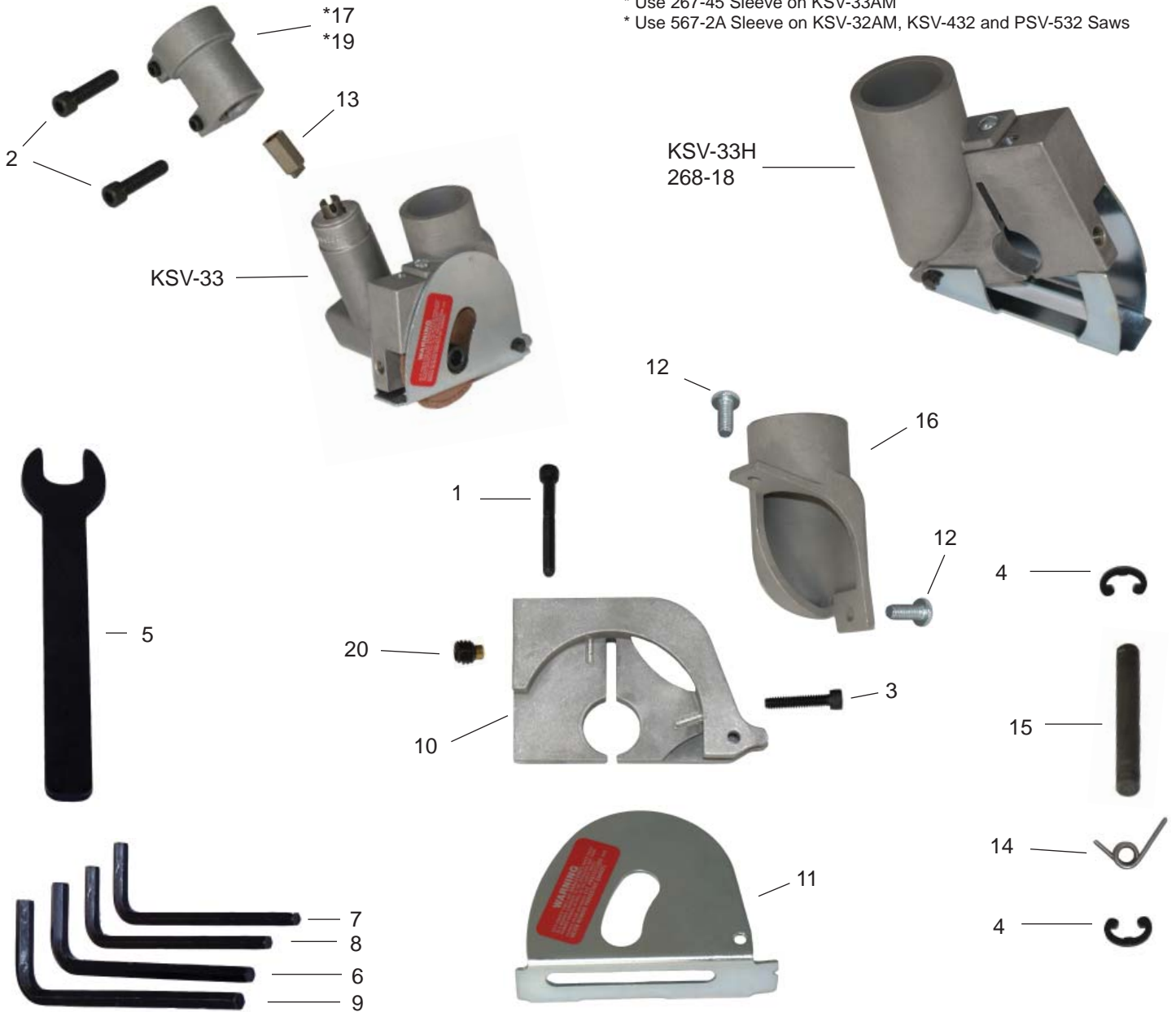

ITEM NO.	PART NO.	DESCRIPTION	REQ'D TOOL	ITEM NO.	PART NO.	DESCRIPTION	REQ'D TOOL
1	133-13	Clamping Screw	1	12	163-48	Screw 10-24 x 1/2	2
2	133-14	Clamping Screw	1	13	170-25	Coupler	1
3	133-29	Screw	1	14	191-12	Coil Spring	1
4	141-10	Retaining Ring	2	15	210-1	Guard Pin	1
5	149-6	Spindle Wrench	1	16	227-2	Vac Head	1
6	150-1	3/16" Socket Key	1				
7	150-2	1/8" Socket Key	1	*17	267-45	Connecting Sleeve	1
8	150-4	5/32" Socket Key	1	18	268-18	KSV-33 Saw Body & Guard Assembly	1
9	150-5	5/18" Socket Key	1	*19	567-2A	Connecting Sleeve	1
10	156-19	Vacuum Saw Body	1	20	N5027	Set Screw	1
11	160-9	Saw Guard	1				

COMPONENT PARTS FOR KRA-5 GEARED ANGLE HEAD

s/n 15241 & higher

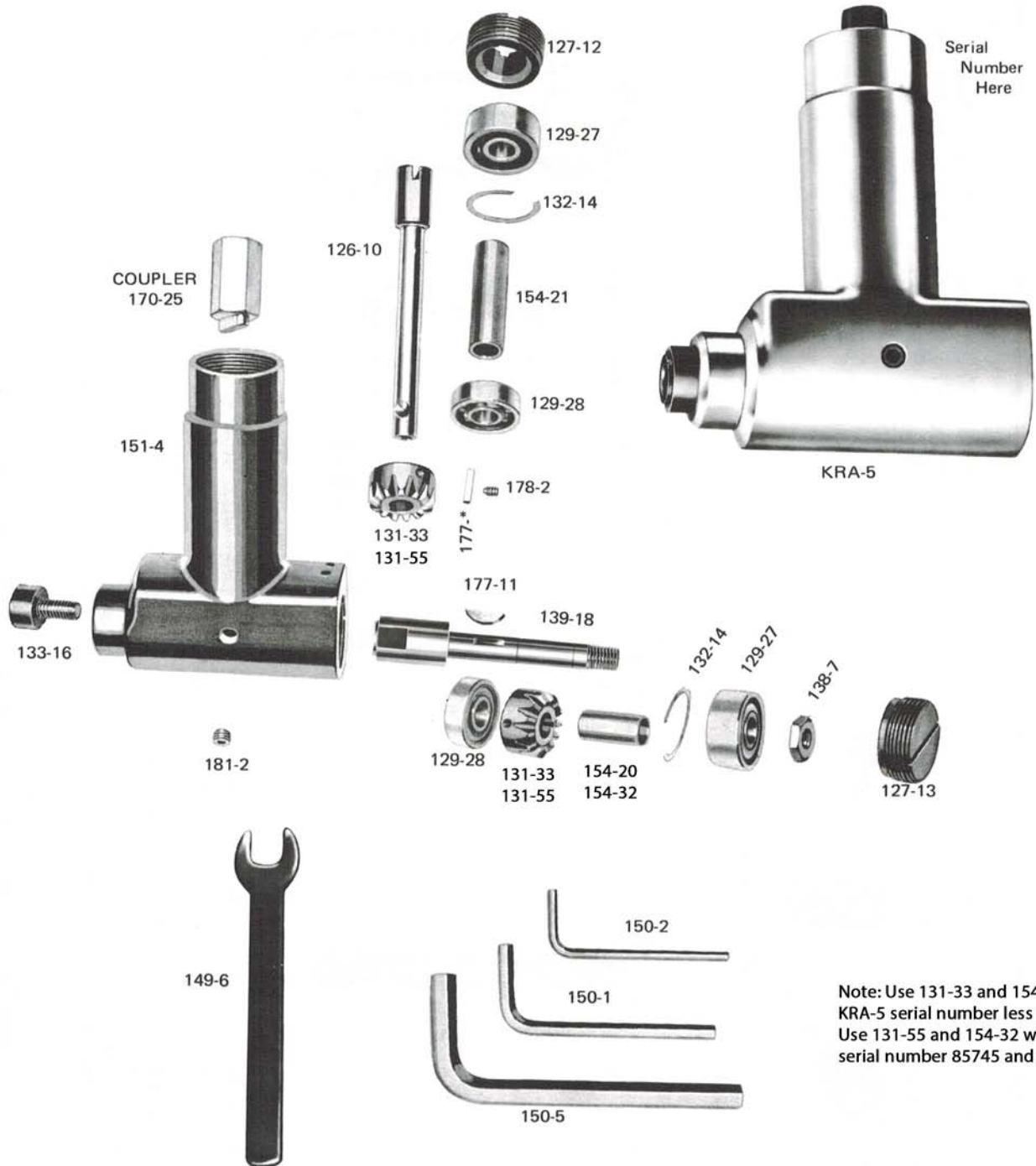

Note: Use 131-33 and 154-20 with KRA-5 serial number less than 85744
Use 131-55 and 154-32 with KRA-5 serial number 85745 and greater.

Part No.	Description	Part No.	Description	Part No.	Description
126-10	Input Spindle	139-18	Output Spindle	177-*	Key (See serial number on neck of KRA-5 above)
127-12	Retaining Screw	149-6	Spindle Wrench		S/N 15240 & lower use 177-7 square key.
127-13	Retaining Screw	150-1	3/16 Socket Key		S/N 15241 & higher use 177-11 Woodruff Key
129-27	Ball Bearing	150-2	1/8 Socket Key		
129-28	Ball Bearing	150-5	5/16 Socket Key		
131-33	Mitre Gear	151-4	Housing	178-2	Socket Head Set Screw
131-55	Mitre Gear	154-20	Sleeve	181-2	Screw Plug
132-14	Shim	154-32	Sleeve		
133-14	Clamping Screw	154-21	Sleeve		
133-16	Spindle Bolt	170-25	Coupler		
138-7	Jam Nut	177-11	Woodruff Key		



KSV-33 Saw Unit

Adjustment Instructions

Installing the KSV-33H (268-18)

To install the KSV-33H onto the KRA-5 (100-7), remove the 227-2 vac head. Unscrew the two 163-48 screws and take off the 227-2. Loosen the 133-29 screw. Slide the KSV-33H onto the KRA-5. Tighten the 133-29 screw and reattach the 227-2 vac head using the two 163-48 screws.

Adjusting the Angle of the KSV-33H

Remove the 227-2 vac head (see above). Loosen the 133-29 screw and rotate the KSV-33H on the KRA-5 to the desired position, being careful to keep the saw blade in line with the vee sight of the saw guard. Tighten the 133-29 screw. Reattach the 227-2 vac head.

Adjusting the Depth of Cut

Loosen the set screw N5027. To increase the depth of cut turn the 133-13 clamping screw counter clockwise. To decrease the depth of cut turn the 133-13 clamping screw clockwise. Once the desired depth of cut is achieved, tighten the N5027 set screw. Ordinarily the saw blade should be extended approximately 1/16" to 1/8" more than the thickness of the material being cut. When cutting through a panel supported by ribs or other understructure that should be unmolested, extend the blade to the same distance as the measured thickness of the material being cut.

Replacing the Saw Blade

Insert the 149-6 open end spindle wrench behind the blade and span the flats on the 139-18 output spindle. Insert the 150-5 socket key into the hex socket of the 133-16 spindle bolt, loosen and remove both the bolt and the blade.

You will note the blade, which has a 7/16" bore, slips over the spindle and seats itself against the shoulder. This design provides for more concentricity resulting in smoother, faster and more accurate cutting. Slip the blade over the spindle, seat it against the shoulder, replace the spindle bolt